

Model Predictive Control (MPC)

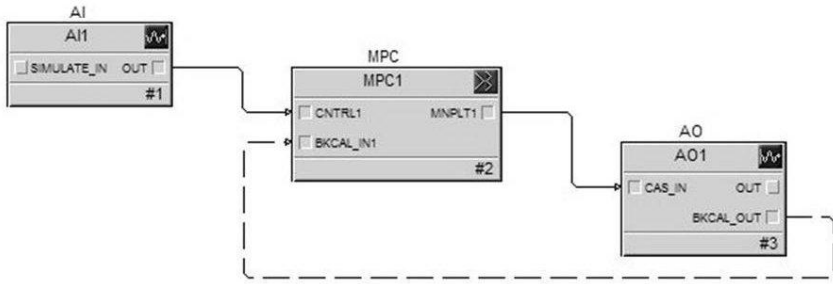

Figure 14-2. MPC Configuration for Single Loop

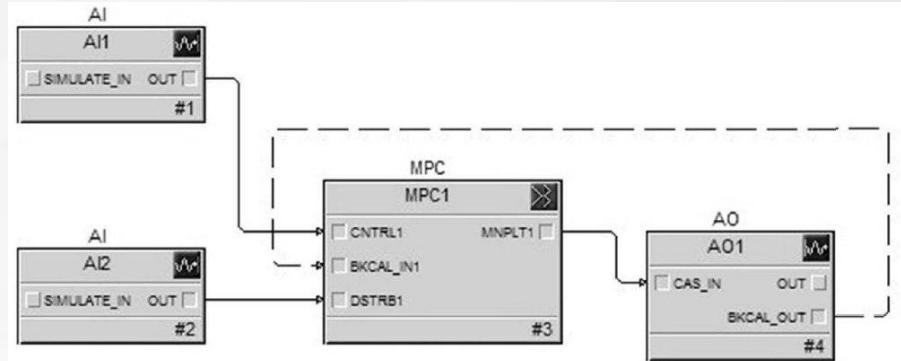

Figure 14-10. Example MPC Implementation for One Measured Disturbance Input

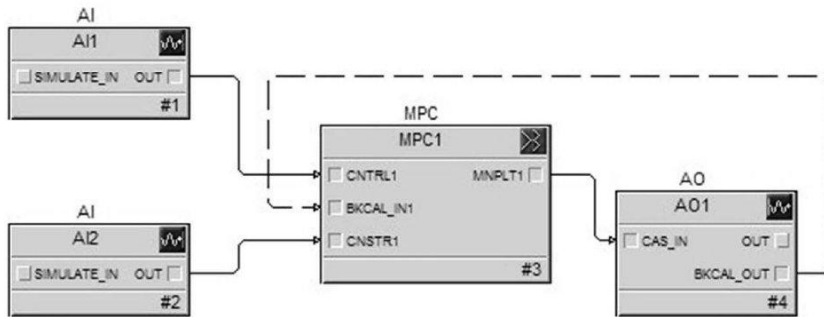

Figure 14-12. MPC Constraint Control

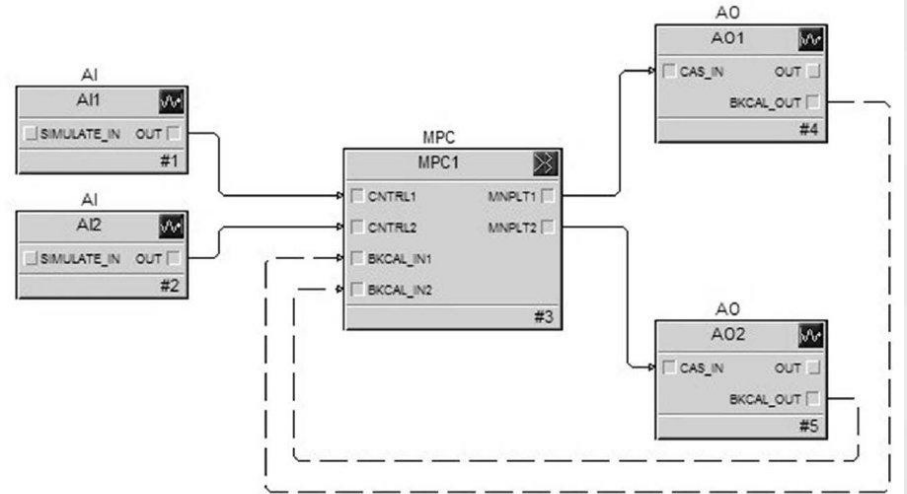

Figure 14-14. MPC Implementation for Interactive Process

MPC May be Layered on Existing Control

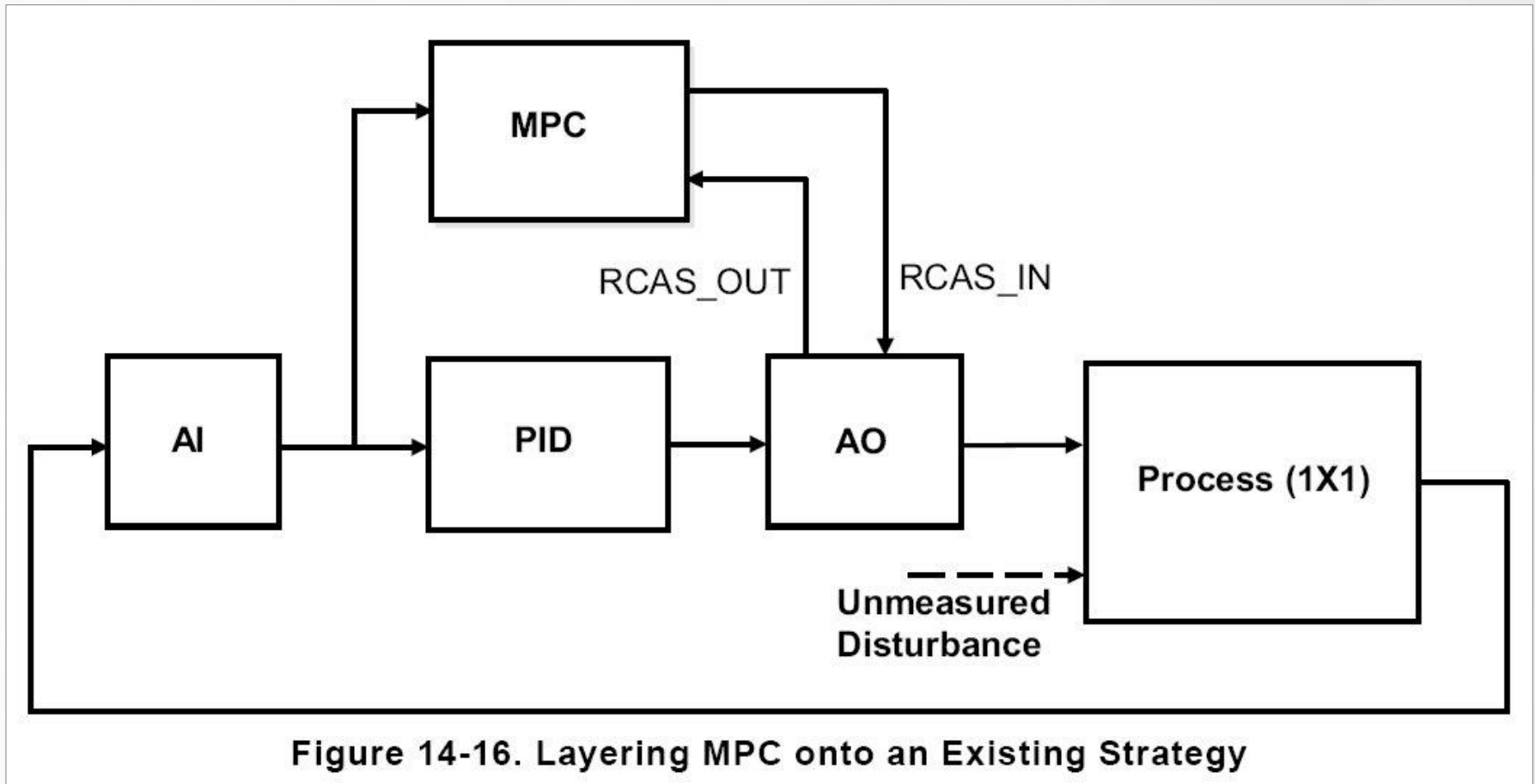

Figure 14-16. Layering MPC onto an Existing Strategy

Workshop – Model Predict Control

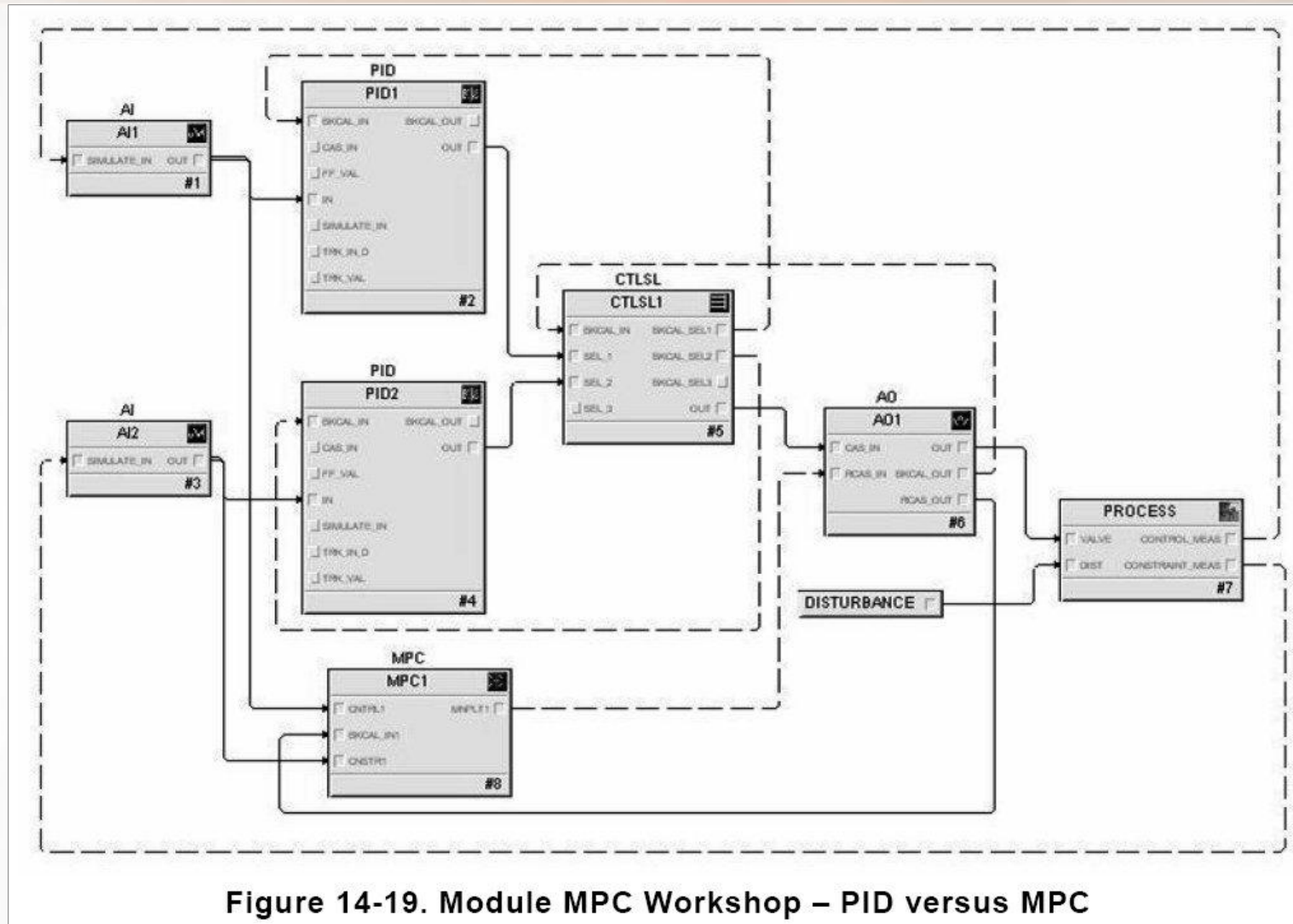

Figure 14-19. Module MPC Workshop – PID versus MPC